



RENAULT  
TRUCKS

PB

PB AUTOMOTIVE GROUP



## RENAULT MASTER RED CCAB 3T5 L3H1 + CITYBOX POLY-LIGHT

### CHASSIS

Wielbasis	4215 mm
GVW	3500 kg
GCW	6000 kg
Eigengewicht	1984 kg
Laadvermogen chassis	1516 kg
Lengte chassis	6360 mm
Cabinebreedte	2080 mm
Hoogte cabine	2257 mm

### MOTOR

Type	2.0L diesel 4 cilinder
Vermogen	170 pk / 132 kW
Koppel	380 Nm
Distributie	Ketting
Versnellingsbak	Automaat 9 versn.

### AFMETINGEN OPBOUW

Inwendige lengte	4200 mm
Inwendige hoogte	2200 mm
Uitwendige breedte	2220 mm
Type	CityBox Poly-Light

### LAADKLEP

Merk	D'Hollandia DH-LMA
Voeding	12V
Platformhoogte	1600 mm
Gewicht DHLMA10	240 kg
Gewicht DHLMA08	195 kg

### UITRUSTING

LED binnenverlichting	Ja
LED zijverlichting	Ja
Airco	Automatisch
Brandstoftank	80 l
AdBlue	25,5 l
Banden	215/75 R16





## RENAULT PLATFORM CABINE - 2 MODELLEN VERKRIJGBAAR

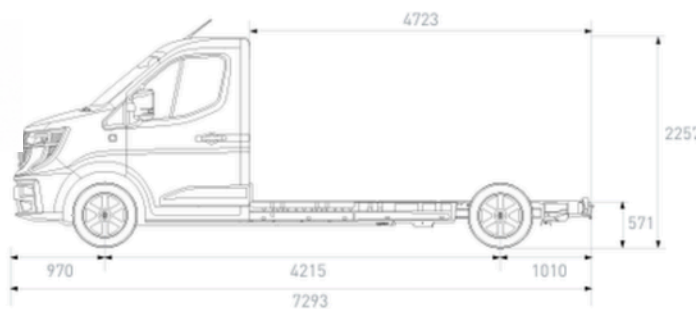

Overhang vóór	
Wielbasis	
Overhang achter	
Totale hoogte	
Totale breedte (uit-/ingeklapte spiegels)	
Chassishoogte	
<b>Gewicht en belastingen</b>	
Max. belasting op vooras diesel	
Max. belasting op achteras diesel	
Max. belasting op vooras 100% elektrische E-Tech	
Max. belasting op achteras 100% elektrische E-Tech	
Getrokken maximummassa (ongeremd/geremd) handgeschakelde versnellingsbak diesel	
Getrokken maximummassa (ongeremd/geremd) 100% elektrische E-Tech	
Max. laadvermogen diesel	
Max. laadvermogen E-Tech 100% elektrisch	
Max. carrosserielengte	

	L2H1		L3H1	
	3,5 t	4,0 t	3,5 t	4,0 t
	5685 mm		6315 mm	
	970 mm			
	3585 mm		4215 mm	
	1130 mm			
	2498 mm		2488 mm	
	2466 mm / 2220 mm			
	571 mm			
	1950 kg	2070 kg	1950 kg	2070 kg
	2100 kg	2370 kg	2100 kg	2370 kg
	2070 kg	2070 kg	2070 kg	2070 kg
	2100 kg	2370 kg	2100 kg	2370 kg
	750 kg / 2500 kg			
	750 kg / 2500 kg*			
	1822 kg	2310 kg	1701 kg	2211 kg
	1521 kg	2016 kg	1463 kg	1949 kg
	3800 mm		4745 mm	



CABINE	COMFORT	MULTIMEDIA	VEILIGHEID	LAADKLEP
• 3 zitplaatsen	• Automatische airconditioning	• 10,1 inch multimediascherm	• ABS	• D'Hollandia DH-LMA
• Verstelbare bestuurdersstoel	• Elektrische ruiten	• Eleordcomputer	• AFU noodremassistent	• Elektrohydraulische laadklep
• Verstelbare stuurkolom in hoogte	• Centrale vergrendeling	• Digitale tachograaf VDO	• Bandenspanningscontrole TPMS	• 12V voeding
• Verstelbare stuurkolom in diepte	• Elektrisch verstelbare buitenspiegels	• Bluetooth connectiviteit	• Rijstrookassistent	• Afstandsbediening
• Stoffen zetelbekleding	• Verwarmde buitenspiegels	• Handsfree telefonie	• Achteruitrijcamera	• Buitenbediening
• Rode veiligheidsgordels	• Regensensor	• USB aansluitingen	• 360° camerasysteem	• Platformhoogte 1.600 mm
• Dashboard met opbergvakken	• Automatische verlichting		• Parkeerhulpcamera	• Aluminium platform
• Dashboardlade 10,7 liter	• Cruise control		• Automatische grootlichten	• 3-delige achterbumper
• Bekerhouders	• Snelheidsbegrenzer			• Gewicht laadklep 195 tot 240 kg afhankelijk van uitvoering
• Opbergvak boven voorruit	• Verkeersbordherkenning			
• Handgreep passagierszijde	• Draadloze smartphone lader			
• Scheidingswand achter cabine	• Start Stop systeem			
• Geïsoleerde achterwandbekleding				





→ L1H1 BESTELWAGEN

→ L2H1 DUBBELE CABINE

→ L2H1 BESTELWAGEN

→ L2H1 COMBI  
(alleen in diesel variant)

→ L2H2 BESTELWAGEN



	Bestelwagen				Bestelwagen dubbele cabine	
	L1H1	L1H2	L2H1	L2H2	L1H1	L2H1
<b>VOORWIELAANDRIJVING</b>						
GCW	3 ton	3 ton	3,1 ton	3 ton	3 ton	3 ton
<b>Afmetingen exterieur</b>						
Totale lengte	5080 mm		5480 mm		5080 mm	5480 mm
Vooroverbouw	1014 mm					
Wielbasis			3498 mm		3098 mm	3498 mm
Achteroverbouw	968 mm					
Totale breedte / met buitenspiegels	1956 / 2283 mm					
Totale hoogte	1971 mm	2495 mm	1967 mm	2498 mm	1971 mm	1967 mm
Draaicirkel tussen trottoirs / tussen muren	6,2 / 6,4 m		6,9 / 7,18 m		6,2 / 6,4 m / 6,9 / 7,18 m	
Min. bodemvrijheid	160 mm					
<b>Gewichten</b>						
Max. draagvermogen vooras	1625 kg					
Max. draagvermogen achteras	1650 kg					
Max. trekgewicht ongeremd/geremd handgeschakeld	750 / 2000 tot 2500 kg*					
Max. trekgewicht ongeremd/geremd EDC	750 / 1680 kg	-	750 / 1680 kg	-	750 / 1680 kg	750 / 1680 kg
<b>Laadruimte (mm)</b>						
Volume laadruimte	5,8 m <sup>3</sup>	6,7 m <sup>3</sup>	7,75 m <sup>3</sup>	8,9 m <sup>3</sup>	3,36 m <sup>3</sup>	4,3 m <sup>3</sup>
Breedte + lengte scheidingswand	510 X 222 mm					
Nuttige binnenlengte bij 1 meter	2537 mm		2937 mm		2023 / 1340 mm / 2423 / 1740 mm	
Nuttige binnenlengte op de vloer inclusief de ruimte onder de bank/doorlaadluik	2950 / 3750 mm		3250 / 4150 mm		-	
Bruikbare hoogte	1387 mm	1898 mm	1387 mm	1898 mm	1387 mm	
Bruikbare binnenbreedte	1462 mm					
Breedte tussen de wielkasten	1248 mm					
<b>Zijschuifdeuren</b>						
Hoogte	1284 mm					
Breedte bij 100 mm / 600 mm	1030 / 907 mm					
<b>Achterdeuren</b>						
Hoogte deuren 180°	1320 mm	1820 mm	1320 mm	1820 mm	1320 mm	1820 mm
Breedte (bij tot 70 mm)	1391 mm					
Laadrempeel	552 mm					

\* M.u.v. 110dk max. 2000ka

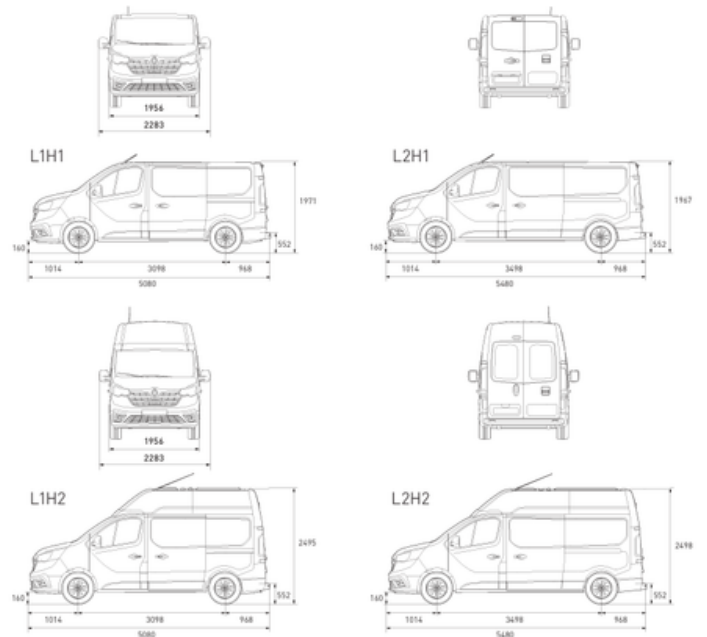



## OVERZICHT UITVOERING

	Bestelwagen		Bestelwagen dubbele cabine	Platform cabine
	L1H1 L2H1	L1H2 L2H2	L1H1 L2H1	L2
Type	Red Edition Red Edition Exclusive	Red Edition	Red Edition Red Edition Exclusive	Red Edition
Handgeschakelde versnellingsbak	110 pk 130 pk 150 pk 170 pk	150 pk 170 pk	110 pk 130 pk 150 pk 170 pk	150 pk 170 pk
Automatische versnellingsbak	150 pk 170 pk	-	150 pk 170 pk	-
GCW	L1H1: 3 ton L2H1: 3.1 ton	3 ton	3 ton	3 ton



**RENAULT  
TRUCKS**

## AANDRIJVING

	110 pk Stop & start	130 pk Stop & start	150 pk Stop & start	170 pk Stop & start
Motorvermogen	4 cilinders / 2,0 L / Single turbo			
Maximumvermogen bij 3500 tpm	81 kW	96 kW	110 kW	125 kW
Maximumkoppel bij 1500 tpm	300 Nm	320 Nm	350 Nm	380 Nm
Type injectie	Common Rail Direct Injection (2500 bar)			
Tankinhoud (Brandstof / AdBlue)	80 L / 24,7 L			
Transmissie	Handgeschakeld 6 versnellingen		Handgeschakeld 6 versnellingen / EDC6 dubbele koppeling	
Standaard	EURO 6 D-FULL			
Cyclus	WLTP (Worldwide harmonized Light vehicles Test Procedures)			
Brandstoffen die voldoen aan de Europese normen waarmee de motoren van in Europa verkochte	<b>B7</b> : EN590 conforme brandstof die maximaal 7% vetzuurmethylesters per volume bevat <b>B10</b> : EN16734 conforme brandstof die maximaal 10% vetzuurmethylesters per volume bevat			



PS AUTOMOTIVE GROUP



ALLE BEDIENINGSELEMENTEN IN DE CABINE BEVINDEN ZICH BINNEN HANDBEREIK VOOR EEN HOGE MATE VAN WERKCOMFORT VOOR DE CHAUFFEUR. RIJHULPSYSTEMEN EN DE AUTOMATISCHE VERSNELLINGSBAK ZORGEN ERVOOR DAT DE CHAUFFEUR ZICH VOLLEDIG KAN CONCENTREREN OP HET WERK EN DE WEG.

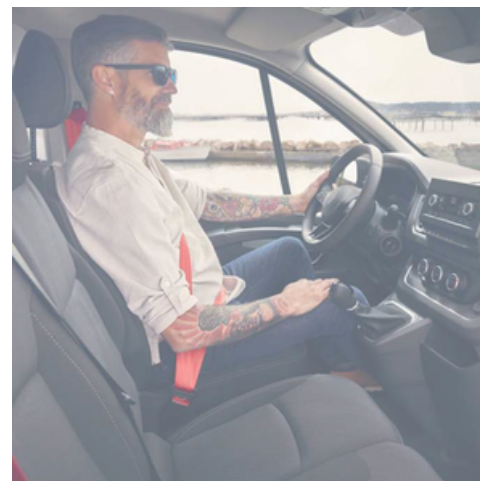



**PB AUTOMOTIVE GROUP**



 +32 472 28 70 30

 ROYERVELD 33, BILZEN - HOESELT

 PBAUTOMOTIVEGROUP@GMAIL.COM

 WWW.PBAUTOMOTIVE.BE